

# HAMMOND TRIMOSAW

## PARTS AND SUPPLY BULLETIN No. ADJ-1146

MODELS A-1, A-2, A-3, A-33, A-34 & A-35 TRIMOSAW  
JUNIOR (J10), AND DIEMAKER TRIMOSAW

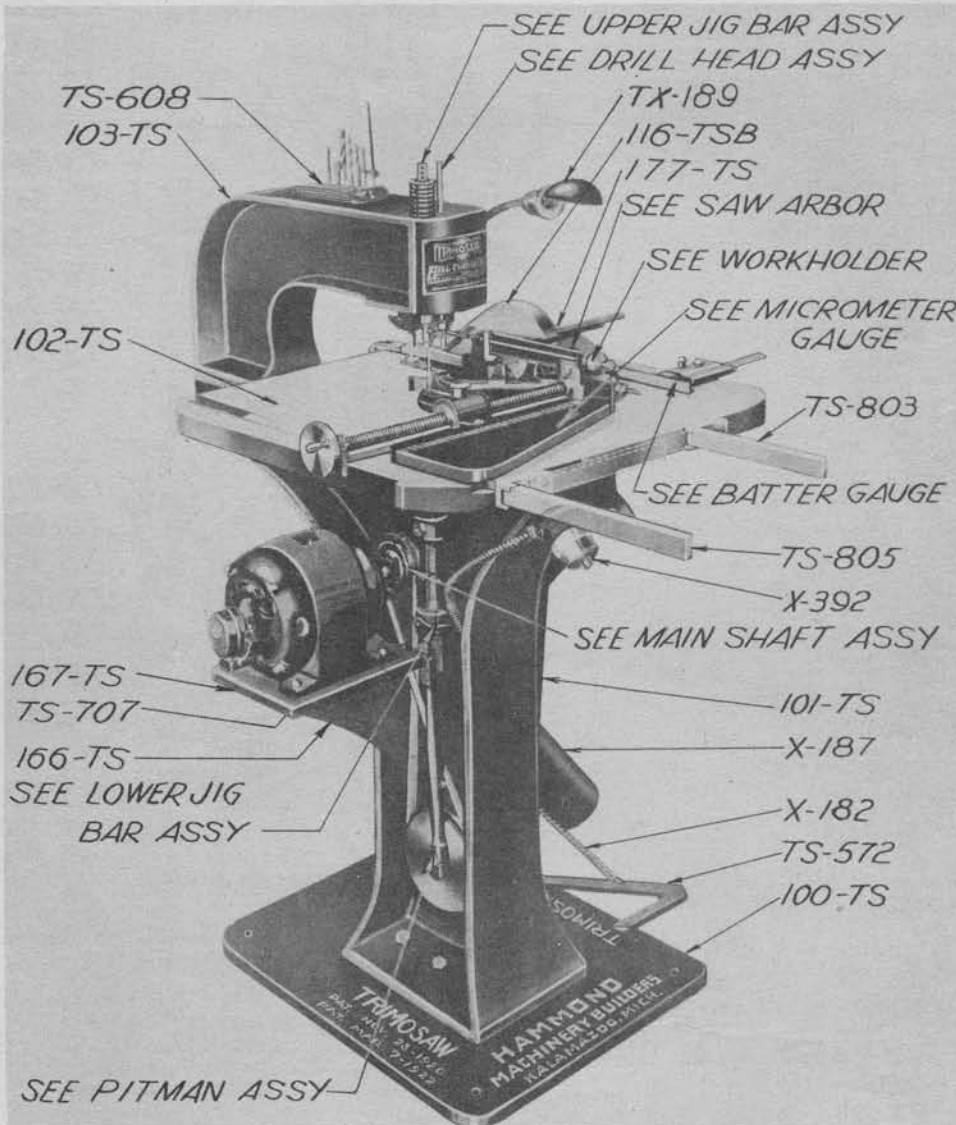

### MODEL A-3 HAMMOND TRIMOSAW

100-TS	Base
101-TS	Pedestal with main shaft and pitman shaft bearings
102-TS	Table
103-TS	Neck
116-TSB	Saw guard with bolt and thumb screw
166-TS	Motor bracket
167-TS	Motor base
177-TS	Door
TS-572	Foot treadle
TS-608	Tool rack
TS-707	Adjusting screws for motor base
TS-803	Bar, R. H. table extension complete
TS-805	Bar, L. H. table extension complete
TX-189	Light fixture complete with clamp
X-182	Chain to drill and router spindle
X-187	Chip pipe
X-392	Switch complete with box and cover

### NOTE:

For parts not listed on photographs, see detailed drawings for part numbers and description.

### WHEN ORDERING PARTS GIVE

- Part Number and Description of Part.
- Machine Model and
- Serial Number

### MODEL A-3 HAMMOND TRIMOSAW

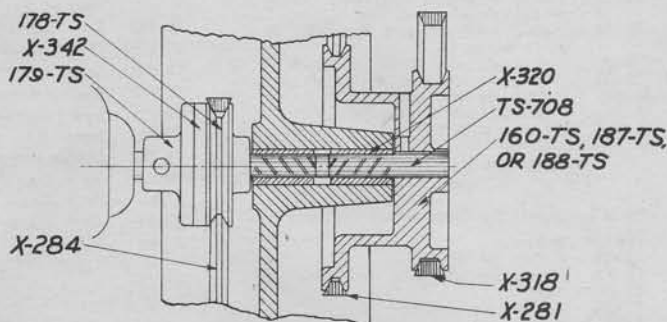

### MAIN SHAFT ASSEMBLY

### MAIN SHAFT ASSEMBLY For all "A" Models

SA-11	Main shaft assembly complete.
160-TS	Pulley for 60 cycle motor, OR
188-TS	Pulley for 40 cycle motor, OR
187-TS	Pulley for 25 or 50 cycle motor
178-TS	Pulley with drive pins, (jig saw drive and coupling)
179-TS	Coupling with drive pins and set screws for motor
TS-708	Shaft, main drive
X-281	V-Belt, main shaft idler
X-284	V-Belt, jig saw drive
X-318	V-Belt, circular saw drive
X-320	Bearing, (set of two)
X-342	Disc, leather

**HAMMOND MACHINERY BUILDERS, INC.**  
1600 DOUGLAS AVE. • • • KALAMAZOO, MICHIGAN

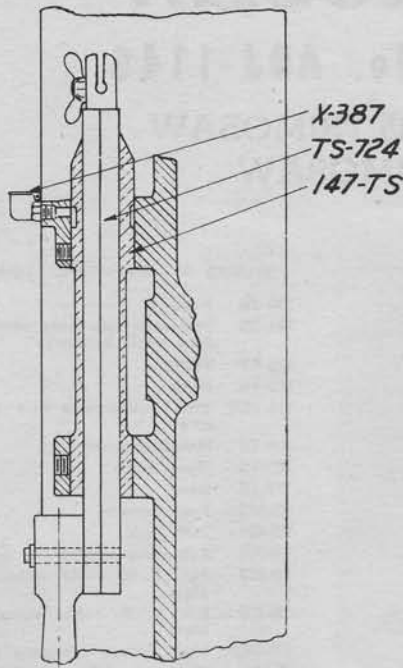

LOWER JIG BAR ASSEMBLY

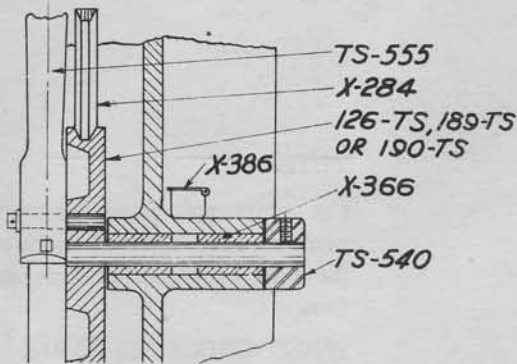

PITMAN ASSEMBLY

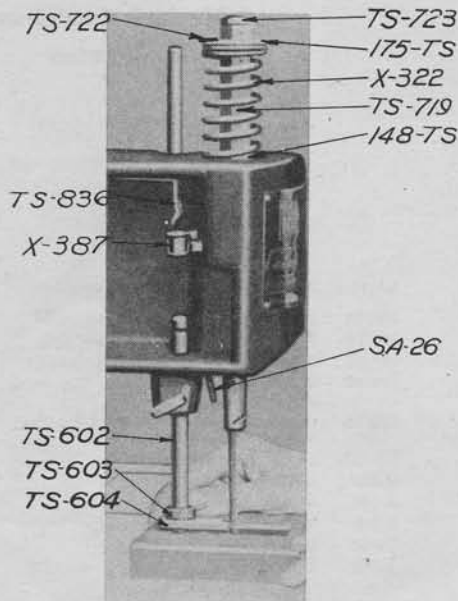

UPPER JIG BAR ASSEMBLY

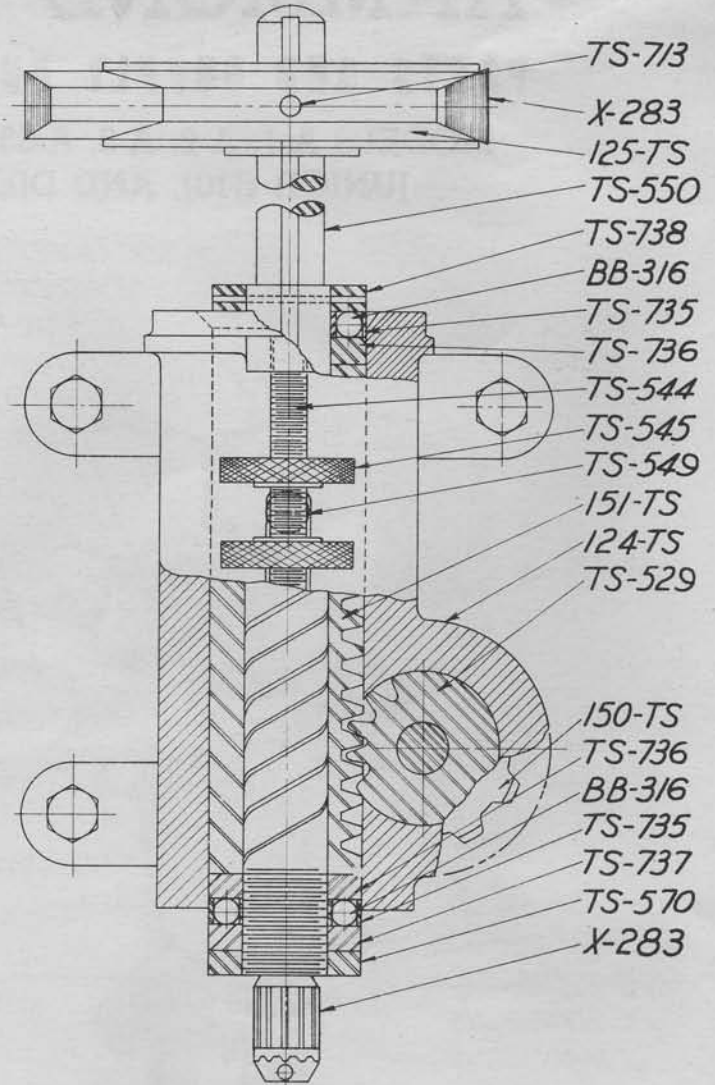

DRILL HEAD ASSEMBLY

**LOWER JIG BAR ASSEMBLY**  
For all "A" and "D" Models

- SA-27 Lower jig bar assembly complete.
- 147-TS Bearing
- TS-724 Lower jig bar with end and pins attached
- X-387 Oiler

**PITMAN ASSEMBLY**  
For all "A" Models

- SA-32 Pitman assembly complete.
- 126-TS Pulley with pin and shaft for 60 cycle motor, OR
- 189-TS Pulley with pin and shaft for 25 or 50 cycle motor, OR
- 190-TS Pulley with pin and shaft for 40 cycle motor
- TS-540 Collar with set screw for shaft
- TS-555 Pitman wood, with bolts
- X-284 V-Belt, jig saw drive
- X-366 Bearing, (set of two)
- X-386 Oil cup with wick

**UPPER JIG BAR ASSEMBLY**  
For all "A" and "D" Models

- SA-24 Upper jig bar assembly complete.
- 148-TS Bearing
- 175-TS Collar for jig bar
- TS-719 Upper jig bar with end attached
- TS-722 Pin
- TS-723 Jig bar wood plug
- X-322 Spring, jig saw
- X-387 Oil cup for bearing
- SA-26 Air pump assembly complete.
- TS-602 Shaft, jig saw foot
- TS-603 Lock nut for TS-602
- TS-604 Foot with fiber piece and roller
- TS-836 Spring clip for jig saw shaft foot

**DRILL HEAD ASSEMBLY**  
For all "A" Models

- SA-31 Drill head assembly complete.
- BB-316 Steel Balls (set of 26)
- 124-TS Drill head
- 125-TS Pulley
- 150-TS Sprocket wheel with pin
- 151-TS Quill
- TS-529 Drill Pinion
- TS-544 Adjusting screw
- TS-545 Nuts for adjusting screw (set of 3)
- TS-549 Stop screw
- TS-550 Drill spindle
- TS-570 Lock collar
- TS-713 Pulley drive pin
- TS-735 Ball retainer
- TS-736 Inner ball race
- TS-737 Lower ball race
- TS-738 Upper ball race with pin
- X-235 Drill chuck
- X-236 Drill chuck wrench
- X-283 V-Belt



**SAW ARBOR ASSEMBLY**

For all "A", "D" and "J" Models

- SA-25 Saw arbor assembly complete.
- 109-TS Saw hanger housing
- 120-TS Sawhead
- 192-TS Collar, grinding wheel
- L-25 Ball bearings
- TS-531B Pulley with arbor
- TS-532 Trimmer tool
- TS-533 Screw, trimmer tool adjusting
- TS-534 Screw, trimmer tool lock
- TS-574 Collar, ball bearing retainer with felt seal
- TS-578 Nut, grinding wheel
- TS-579 Spacer, bearing
- TS-610 Nut, collar lock
- TS-796 Pin, trimmer tool drive
- X-166 Grinding wheel, straight
- X-286 Bumper, rubber
- X-388 Oil cup

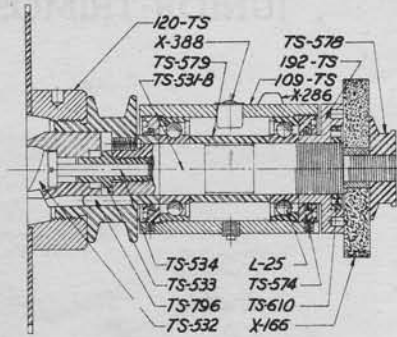

**SAW ARBOR**

**SAW IDLER PULLEY ASSEMBLY**

For all "A", and "J" Models

- SA-40 Saw idler pulley assembly plus holder and shaft.
- 108-TS Saw hanger holder
- 162-TS Hanger shaft arm with bolts
- 163-TS Idler pulley arm
- 191-TS Idler pulley
- TS-686 Shoulder bolt
- TS-687 Collar
- TS-694 Shaft, saw hanger
- TS-800 Pulley cap
- PX-207 Oiler
- PX-231 Bearings
- PX-230 Felt, bearing seal

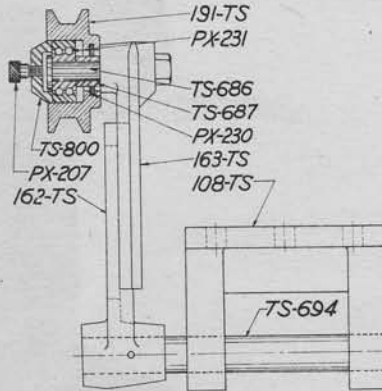

**SAW IDLER PULLEY ASSEMBLY**

**SAW GRINDING AND TRUING DEVICE**

For all "A", "D" and "J" Models

- SA-36 Saw grinding and truing device complete.
- 183-TS Wheel testing gauge
- 184-TS Slide with pins
- TS-523 Lock screw
- TS-545 Lock screw nut
- TS-635 Slide bar with pins
- TS-640 Stop screw
- TS-700 Stop screw nut (set of two)
- TS-752 Index plate with pins (for 35 and 70 tooth blade)
- TS-756 Adjusting screw with head
- TS-759 Stud with wing nut
- TS-769 Index plate with pins (for 36 tooth blade)
- TS-770 Post adjusting screw
- TS-775 Saw head post
- X-293 Bolt, holding grinder to table
- X-294 Saucer grinding wheel for 70 tooth blade
- X-360 Spring with connecting pins

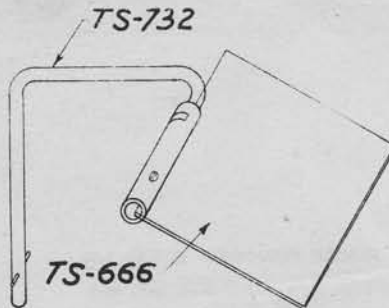

**SEE THRU GUARD**

**SEE-THRU GUARD**

For all "A", "D" and "J" Models

- SA-29 See-thru guard assembly complete.
- TS-666 Pyralin guard
- TS-732 Arm with thumb screw and clamp

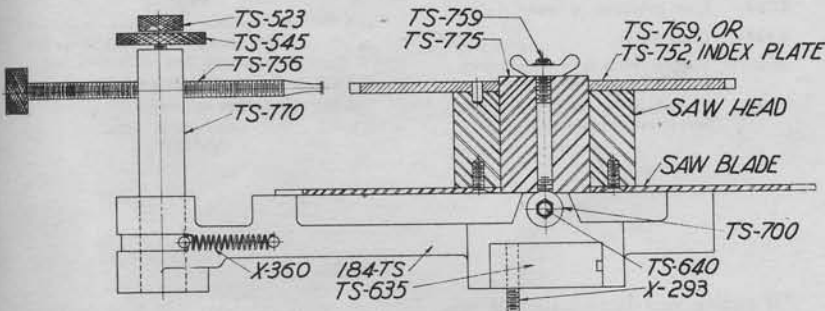

**SAW GRINDING AND TRUING DEVICE**

# JUNIOR TRIMOSAW MODEL J-10

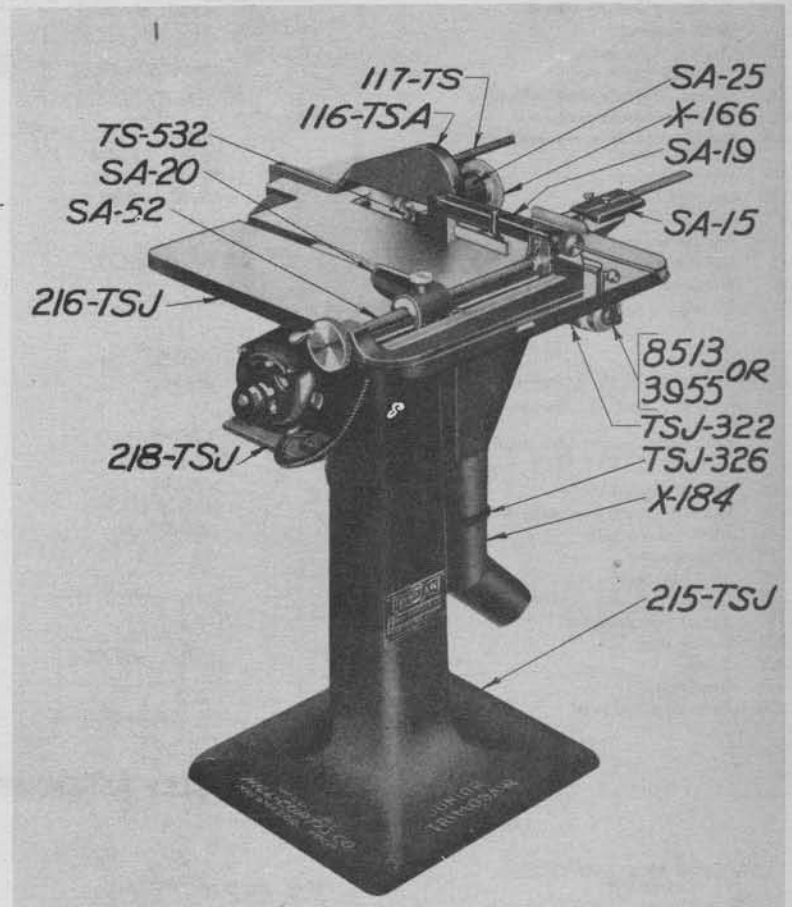

## JUNIOR TRIMOSAW MODEL J-10

116-TSA	Saw guard with bolt and thumb screw
177-TS	Door with hinge rod
215-TSJ	Pedestal
216-TSJ	Table
217-TSJ	Pulley for 60 cycle motor
218-TSJ	Bracket, motor
219-TSJ	Pulley for 25 or 40 cycle motor
TSJ-322	Bracket for switch
TSJ-326	Strap for chip pipe
TS-532	Trimmer tool
X-166	Flat grinding wheel
X-184	Chip pipe
3955	Switch with box and cover for single phase motor
8513	Switch with box and cover for three phase motor

Parts for the following Sub-Assemblies are listed with the "A" Models

SA-15	Batter gauge
SA-19	Workholder clamp
SA-20	Measuring finger
SA-22	Light fixture
SA-25	Saw arbor assembly
SA-29	See-thru guard
SA-36	Saw grinding and truing device
SA-40	Saw idler pulley assembly
SA-52	Micrometer gauge assembly complete, but without finger and clamp. Same as furnished with "A" Models, see SA-18, except
206-TSJ	Micrometer gauge, without parts assembled, but with finger guide bar and slot bar
TSJ-300	Micrometer screw
TSJ-301	Bushing, micrometer screw
SA-473	Left hand miter vise

All parts not listed under above sub-assemblies are the same as those listed with Model A-3

# DIEMAKER TRIMOSAW

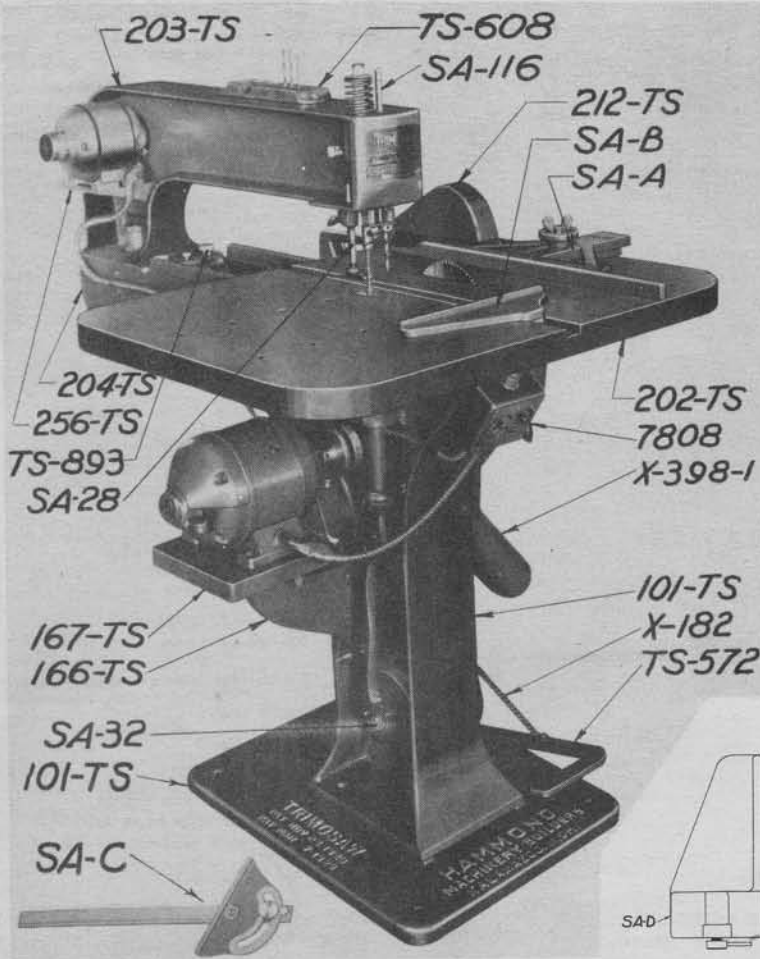

## DIEMAKER TRIMOSAW

100-TS	Base	212-TS	Saw guard with bolt and thumb screw
101-TS	Pedestal with X-320 Main shaft bearing, (set of 2)	256-TS	Bracket, drill motor
	X-366 Pitman shaft bearing, (set of 2)	TS-572	Foot treadle
166-TS	Bracket, main motor drive	TS-602	Shaft, jig saw foot
167-TS	Motor plate, main motor drive	TS-603	Lock nut for TS-602
202-TS	Table	TS-604	Foot with fiber piece and roller
203-TS	Neck	TS-608	Tool rack
204-TS	Neck Extension	TS-820	Protecting piece for king pin
209-TS	Pulley, drill motor, for 60 cycle motor, OR	TS-825	Idler stud
222-TS	Pulley, drill motor, for 50 cycle motor	TS-893	Neck locating pin
		TS-922	Chip pipe strap
		TS-924	Shaft, chain idler pulley
		X-182	Drill chain
		X-398-1	Chip pipe
		7808	Switch, complete with box and cover

All parts not listed under above sub-assemblies are the same as those listed with Model A-3

## SUPPLY ITEMS

### JIG SAW BLADES

X-191A	1/8" two point
X-191	1/8" three point
X-192A	3/16" two point
X-192	3/16" three point
X-193	1/4" three point
X-399	1/8" fine tooth
X-355	3/16" four point stereotype
X-356	1/4" six point stereotype
X-209	Broach

### ROUTER BITS

X-194	1/16" wide
X-195	1/8" wide
X-402	1/4" wide

X-260	1/2" wide
X-261	3/4" wide
X-269	3/8" beveling tool
RS-516	Tri-Point planner tool
TS-599	Type-High gauge

### DRILLS

X-197	12 point drill
X-198	15 point drill
X-199	18 point drill

### MISCELLANEOUS ITEMS

BX-259	Saw swaging tool
TS-807	Spanner wrench
X-236	Drill chuck wrench

### SIDE RIPPING GAUGE

SA-A	Side ripping gauge complete.
215-TS-1	Slide with slide bar
216-TS-1	Base
217-TS	Thumb nut for stud
218-TS	Hand wheel
TS-840	Gear
TS-841-1	Rack gear with pins
TS-842	Stud

### CROSS CUTTING GAUGE

SA-B	Cross cutting gauge complete.
TS-885	Gauge finger bar

### SWIVEL GAUGE

SA-C	Swivel gauge complete.
------	------------------------

243-TS	Swivel cross gauge
TS-569	Lock screw, swivel gauge
TS-829	Slot bar assembled with hinge pin
TS-831	Pointer
TS-885	Gauge finger bar

### GAUGE FINGER

SA-D	Gauge finger complete for SA-B and SA-C
------	---

244-TS-1	Gauge finger
SS-141	Clamp, gauge finger
SS-142	Clamp screw with pin

### LOWER JIG SAW GUIDE

SA-54	Lower jig saw guide assembly complete.
TS-605	Jig saw roller with pin
TS-832	Lower jig saw guide with stud and nut

### DRILL HEAD ASSEMBLY

SA-116	Drill head assembly, complete.
253-TS	Drill head
254-TS	Pulley

255-TS	Quill
257-TS	Bushing seal
GB-525	Oiler, depressed ball type for 255-TS
TS-880	Drill pinion
TS-881	Stop screw
TS-887	Lock collar
TS-911	Drill spindle
TS-912	Bearing cap, upper
TS-913	Bearing cap, lower
TS-917	Belt guard, for 60 cycle motor, OR
X-411	Belt guard for 25 or 50 cycle motor
UG-1805	Oil cup for drill
7012	Ball bearings, lower
7025	Ball bearings, upper
X-235	Drill chuck
X-236	Drill chuck wrench
X-283	V-Belt, drill motor to drill head

### PARTS FOR THE FOLLOWING SUB ASSEMBLIES ARE LISTED WITH THE "A" MODELS

SA-11	Main shaft assembly complete. Same as furnished with "A" Models, except
206-TS	Double drive pulley for 60 cycle motor, OR
222-TS	Double drive pulley for 25 and 50 cycle motors.
SA-24	Upper jig bar assembly
SA-25	Saw arbor assembly
SA-26	Air pump assembly
SA-27	Lower jig assembly
SA-29	See-Thru guard assembly
SA-32	Pitman assembly complete. Same as furnished with "A" Models except
207-TS	Jig saw pulley with shaft and pin
SA-40	Saw idler pulley assembly. Same as furnished with "A" Model, except
108-1-TS	Saw hanger holder
TS-837	Stud for saw hanger

### SAW BLADES

X-384	7" dia. 70 ground teeth hard metal for slugs
X-295	7" dia. 70 swaged teeth for slugs
X-407	7" dia. 35 swaged teeth for stereotypes
X-289	7" dia. 70 set teeth for wood
X-347	6 1/2" dia. 122 set teeth for zinc

### GRINDING WHEELS

X-166	Flat grinding wheel
X-294	Wheel for grinding 70 tooth saw blades
X-371	Wheel for grinding 35 tooth saw blades
X-348	Grinding wheel dresser

### BELTS

X-318	Vulcanized endless V-Belt for circular saw
X-318L	Leather lug type V-Belt for circular saw
X-281	Leather V-Belt, main shaft to idler
X-282	Leather V-Belt, pedestal idler to neck idler
X-283	Leather V-Belt, to operate drill head
X-284	Leather V-Belt, to operate jig saw